

# A Network-based System Architecture for Remote Medical Applications

Huimin She<sup>1,2</sup>

<sup>1</sup>Dept. of Electronic, Computer and Software Systems, Royal Institute of Technology, Sweden

<sup>2</sup>ASIC & System State Key Lab., Dept. of Microelectronics, Fudan Univ., Shanghai, China  
Tel: +46-8-790-4247

huimin@kth.se

Axel Jantsch, Li-Rong Zheng

Dept. of Electronic, Computer and Software Systems, Royal Institute of Technology, Sweden  
Tel: +46-8-790-4124, +46-8-790-4104

{axel, lrzheng}@kth.se

Zhonghai Lu

Dept. of Electronic, Computer and Software Systems, Royal Institute of Technology, Sweden

Tel: +46-8-790-4110

zhonghai@kth.se

Dian Zhou

ASIC & System State Key Lab., Dept. of Microelectronics, Fudan Univ., Shanghai, China

Tel: +86-21-5135-5286

zhoud@fudan.edu.cn

## ABSTRACT

Nowadays, the evolution of wireless communication and network technologies enables remote medical services to be available everywhere in the world. In this paper, a network-based system architecture adopting wireless personal area network (WPAN) protocol IEEE 802.15.4/Zigbee standard and 3G communication networks for remote medical applications is proposed. In the proposed system, the number and type of medical sensors are scalable depending on individual needs. This feature allows the system to be flexibly applied in several medical applications. Furthermore, a differentiated service using priority scheduling and data compression is introduced. This scheme can not only reduce transmission delay for critical physiological signals and enhance bandwidth utilization at the same time, but also decrease power consumption of the hand-held personal server which uses battery as the energy source.

## Categories and Subject Descriptors

J.3 [Computer applications]: Life and Medical Sciences – medical information systems

## General Terms

Design, Performance

## Keywords

System architecture, Sensor network, Remote medical applications

## 1. INTRODUCTION

In medical applications, collecting patient physiological information timely is crucial for clinicians to make treatment advices in time, which is of large importance for saving lives and ensuring patient's safety. The development of wireless communication and network technologies has made a significant impact on remote medical applications during last few years [9]. It makes remote health care at home or in the hospital practically feasible and comfortable. Although face-to-face communication between a patient and a clinician can not be replaced, there are efficient and flexible ways to provide remote medical care by adopting wireless telemedicine which has many advantages. Firstly, clinicians can read patients' physiological parameters in time and then give real-time diagnosis advices which are important to patients' recovery. Secondly, patients can measure their physiological signals and then send them to the hospital remotely without the necessity to go to the hospital. Thirdly, patients can move around freely while carrying wireless hand-held medical devices. And finally, with the help of this system, a clinician can take care of a few patients simultaneously, and thus the personnel expense will be reduced.

In traditional approaches, remote medical services are implemented over wired communication technologies like the Integrated Services Digital Network (ISDN) [5] [7]. Most current telemedicine applications are limited to communications between fixed locations with conventional handsets. These heavy medical devices will prevent the patients from moving around freely. In [3], some ongoing and emerging applications of wireless information technology in health care are investigated. With the development of mobile communication technologies, such as GSM, GPRS, especially 3G networks, wireless medical service can be delivered to any locations flexibly. In recent years, there are many new applications in health provision using mobile technology [1] [2] [10]. 3G communication network provides a broadband, packet-based transmission of text, digitized voice, video, and multimedia at data rates up to 2 Mbps. It offers a consistent set of services to mobile computer and phone users no

*Copyright is held by the author/owner(s)*

*Asia Pacific Advanced Network 2007, 27-31 August 2007, Xi'an, People's Republic of China.*

*Network Research Workshop, 27 August 2007, Xi'an, People's Republic of China.*

matter where they are located in the world. In [14], a portable teletrauma system using commercially available 3G wireless cellular data services is introduced. However, they did not mention the communication between medical sensors and the trauma-patient unit.

In this paper, a network-based system architecture for remote medical applications using low power IEEE 802.15.4/Zigbee standard and commercially available 3G networks is proposed. In our proposed system, the number and type of medical sensors are scalable depending on individual requirements. This feature allows this system to be flexibly applied to a wide range of medical applications such as continuous home monitoring and in-hospital health care. Moreover, a differentiated service using data compression and priority scheduling is introduced. This scheme can reduce transmission latency for critical physiological signals and decrease power consumption of the hand-held personal server which uses battery as the power source.

The rest of this paper is organized as follows: In section II, the system architectures including medical sensors, the personal server and the differentiated service are presented. In section III, an example use case is discussed. Finally, conclusions are made in section IV.

## 2. SYSTEM ARCHITECTURE

### 2.1 Overview of system architecture

The whole system architecture is shown in figure 1. It is composed of medical sensor nodes, a hand-held personal server, a hospital server and related services. In this system, medical sensor nodes are used to collect physiological signals including bio-signals, medical images, and voice signals. These obtained signals are fed into the personal server through wireless personal area network (WPAN). The wireless communication between the sensor nodes and the hand-held personal server uses IEEE 802.15.4/Zigbee standard. Then the hand-held personal server processes the data and displays the results on its LCD screen. And the data can be stored in a local memory for self recording. If necessary or required, the data can be transmitted to the hospital server via 3G communication networks. With the availability of 3G networks, digitalized data and voice can be transmitted simultaneously. After arriving at the hospital server, the data are either stored in the clinical data base, or available to a clinician through a hospital's local area network (LAN). Then clinicians can analyze the physiological data and give diagnosis advices accordingly. Alternatively, when a clinician is away from the hospital, he/she still can get the data via a PDA and give diagnosis advices to the patient remotely.

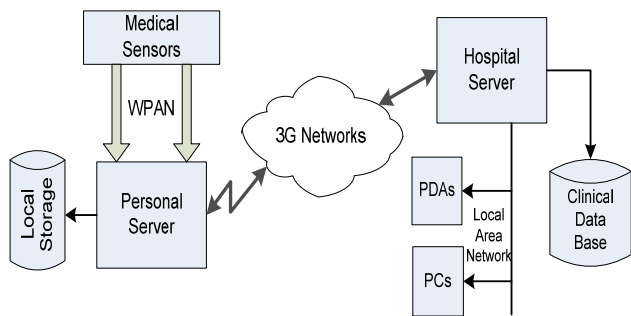

Figure 1. The system architecture

In this system, the number and type of medical sensor nodes to build the local personal network are variable depending on individual's needs. This feature makes the system flexible with a lot of medical applications such as remote health care, home monitoring, disaster and emergency monitoring. Furthermore, this system provides convenience for patients as well as for clinicians. For patients, they can get medical service at home or any other places they prefer. And they can move around freely while carrying light hand-held medical device. For clinicians, they can give diagnosis suggestions to patients remotely without the necessity to go to the hospital if nothing emergency happens. In the following three sub-sections, more detailed descriptions about medical sensors, the hand-held personal server, and the differentiated service will be presented.

### 2.2 Medical sensors and wireless personal area network

The main tasks of the medical sensors are to collect physiological signals and send them to the personal server. Typical medical sensors and characteristics of the signals are shown in table 1 [13]. In this system, the type and number of medical sensors are scalable depending on applications. Several commonly used medical sensors are briefly introduced as follows:

- 1) Electrocardiography (ECG) is the most widely used technique for cardiac disease diagnosing. The researchers in Harvard University have developed sensor boards for both the Mica2/MicaZ and Telos mote platforms that provide continuous ECG monitoring by measuring the differential across a single pair of electrodes [12].
- 2) Electroencephalograph (EEG) is the neurophysiologic measurement of the electrical activity of the brain by recording from electrodes placed on the scalp. It is capable of detecting changes in electrical activity in the brain on a millisecond-level.
- 3) Electrooculography (EOG) is a technique for measuring the resting potential of the retina. The resulting signal is called the electrooculogram. The main applications are in ophthalmological diagnosis and in recording eye movements.
- 4) Electromyogram (EMG) is a medical technique for evaluating and recording physiologic properties of muscles at rest and while contracting.

Table 1. Characteristics of biomedical signals

Signal	Frequency Range	Signal Range
Electrocardiograph (ECG)	0.05~100 Hz	0.01~5 mV
Electroencephalograph (EEG)	0.5~60 Hz	15~100 mV
Electrooculogram (EOG)	0.5~50 Hz	N/A
Electromyogram (EMG)	0.5~60 Hz	N/A
Heart Rate	45~200 beats/min	N/A
Breathing Rate	12~40 breaths/min	N/A
Blood pressure	dc-60 Hz	40~300mmHg

Depending on the characteristic of digitized physiological signals, a low data rate, short range and low power protocol is appropriate for the data transmission between medical sensors and the personal server. The IEEE 802.15.4/Zigbee standard is adopted in this system. The IEEE Standard 802.15.4 describes a very low rate wireless technology that is designed for communication among wireless devices within a short range, using very low power and with low data rate requirements [11]. In [6], IEEE 802.15.4 standard is utilized for medical sensor body area networking. And the performance of this protocol is analyzed. The simulation results show that IEEE Std. 802.15.4 can be used for medical sensor networking with low data rate asymmetric traffic when properly configured.

In the proposed system, various sampling rates and quantization levels are used when the biomedical signals are digitized before sent to the hospital server. Taking ECG as an example, a relatively low sampling frequency of 128 Hz is appropriate for a good representation of ECG signals, while a sampling rate of 250Hz with 16-bit resolution has been used in ECG characterization processing. From table 1, we can see that ECG generates the highest data rate among the patient's vital signals, which is about 10 kB/s. Then the low data rate wireless technology IEEE 802.15.4/Zigbee standard, which supports data rate of 250 kbit/s at 2.4GHz frequency band, can be adopted for communication between medical sensors and the personal server.

### 2.3 The personal server

Previous descriptions show that the personal server plays an important role in overall telemedicine system. It is designed as a hand-held unit which can be used to communicate parallelly with a series of scalable medical sensor nodes as well as a remote hospital server. It maintains a communication bridge between patients and the hospital. Medical sensors start to collect data (such as ECG) after getting the command from the personal server and then send it to the personal server via wireless personal area network (WPAN). Results (e.g. body temperature or blood pressure) can be displayed on LCD screen of the personal server. And data may be sent to the remote hospital server for further processing if necessary. In general, the personal server performs the following tasks: 1) Initialization and configuration of medical sensor nodes. 2) Collecting data from medical sensors. 3) Processing physiological data and displaying results. 4) Keeping reliable communication with remote hospital server. 5) Providing a graphic user interface. 6) Providing voice communication between patients and physicians.

The diagram of the personal server is shown in Figure 2. The main components of the personal server are listed as follows:

- 1) Processor & Memory module: The processor manages the connections and data flow among all modules. It also takes charge of initialization and configuration of connected medical sensor nodes.
- 2) User Interface: The LCD screen is used for showing measurement results (e.g. body temperature) and the keyboard is used to input request from patient. For example, for heart disease patients, an ECG measurement or blood pressure testing can be taken if required.
- 3) Communication module: This module consists of two sub-modules—a data transceiver and a Zigbee module, which respectively manage communicating with the hospital server

and medical sensor nodes. The data transceiver sub-module is used to transmit data to the hospital server as well as get command from it. The Zigbee sub-module is used to communicate with medical sensor nodes which require a low data rate and short range communication link. To reduce power consumption, in this design, IEEE 802.15.4/Zigbee standard is adopted for the communication between medical sensor nodes and the hand-held personal server.

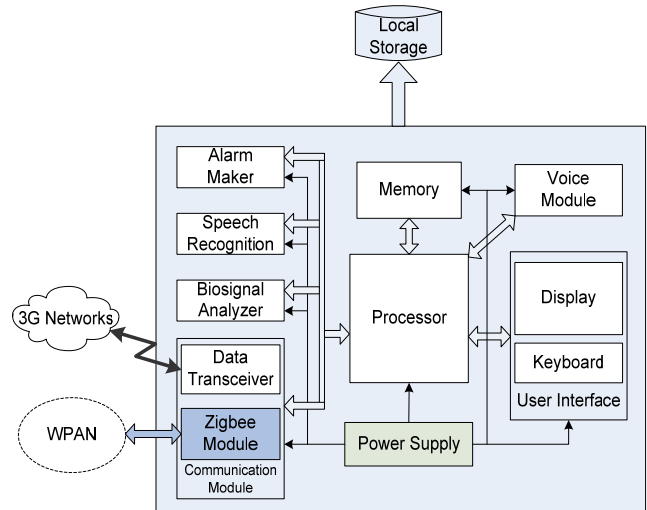

Figure 2. Diagram of the personal server

- 4) Bio-signal Analyzer: The main tasks of the personal server are to collect and process physiological data from medical sensor nodes. Bio-signal analyzer module is used to analyze bio-signals and performs parameter extraction under the remote clinician's request. For example, among the patient's vital signals, ECG generates the highest data rate, which is about 10 kB/s. R-interval analysis can be performed to determine the peaks through setting the threshold and first derivative for a standard peak function. By transmitting certain R-intervals instead of the whole ECG waveform, the data rate can be lowered and power consumption can be reduced subsequently.
- 5) Speech Recognition: This module is used to record voice signals and sounds from the patient especially during sleeping-time. When there are abnormal snoring sounds, alarms will be made to inform the care giver or wake up the patient himself/herself.
- 6) Alarm Maker: If one of the physiological signals exceeds the threshold that is pre-set, this module will make alarms to inform the clinician or a care giver. Then the patient will get corresponding treatment in time.
- 7) Voice Module: This module is used to provide voice communication between the hand-held personal server and the hospital. Conversations can be started by either side. With the help of this module, the patient can communicate with the physician more directly and effectively.
- 8) Power Supply: This module is used to provide energy for other modules.

## 2.4 Differentiated services

Among patients who had heart attacks, about 30% of them died even before reaching the hospital [8]. Although heart attack can happen suddenly without apparent indications, if correct instructions can be made immediately, then mortality can be reduced. So providing timely access to patient information is crucial for saving lives and ensuring patients' safety. Therefore, providing guaranteed service and reducing transmission latency for critical physiological signals is of great importance for life-threatening medical applications. On the other hand, since the personal server is powered by battery, power consumption has great impact on the efficiency of wireless personal area network (WPAN) and prolonging the working time of the personal server. As all know, reducing the transmission period will improve overall bandwidth utilization as well as decrease power consumption. In order to reduce transmission delay for critical physiological signals, improve overall bandwidth utilization and reduce power consumption, a differentiated service based on two schemes --- priority scheduling and data compression --- is proposed.

### A. Priority scheduling & data compression

Depending on the characteristics of different physiological signals, the traffic from medical sensors is divided into four types according to their data rates and latency requirements. The four types of traffic are: 1) high data-rate and low latency traffic; 2) low data-rate and low latency traffic; 3) low data-rate and high latency traffic; 4) high-data rate and high latency traffic. Low latency means that the signal is critical, and its transmission delay should be as short as possible. Each type of traffic is assigned a priority weight which implies its transmission order when there are several types of physiological signals to be sent. In table 2, an example of priorities for different traffic types is shown. However, the 'high' and 'low' defined here are relative. And the priority weight can be assigned dynamically during the initialization process of the personal server according to a specific application. For example, when monitoring heart disease patients, ECG has the highest priority; while monitoring head disease patients, EEG has the highest priority and so on. For high data-rate and high latency signal (such as medical image), it will be compressed according to a given ratio and stored in local memory until its deadline expired. And for other signals, they will be sent out immediately according to their priority orders.

**Table 2. Priorities for different traffic types**

Data Type	Data rate	Latency	Priority
ECG	High	Low	1
EEG, EOG, EMG	Low	Low	2
Heart rate & Blood pressure & Body temperature	Low	High	3
Medical Image	High	High	4

### B. The differentiated service

A flowchart of the differentiated service is shown in figure 3. The personal server has two working modes, which are inactive mode and active mode. When there is no workload, the personal server will turn into inactive mode to save energy. And if there is workload, the personal server wakes up from inactive mode and is ready for transmission. If the physiological signals are critical, they will be sent to the hospital server according to their priority

orders. From previous definitions, we know that physiological signals with low latency requirement are critical signals and others are non-critical signals. For non-critical physiological signals, they will be compressed according to a given compression ratio and then stored in local memory. If there is no other data to send, non-critical physiological signals will be sent to the hospital immediately. Otherwise, they will not be sent to the hospital server until their deadlines expired.

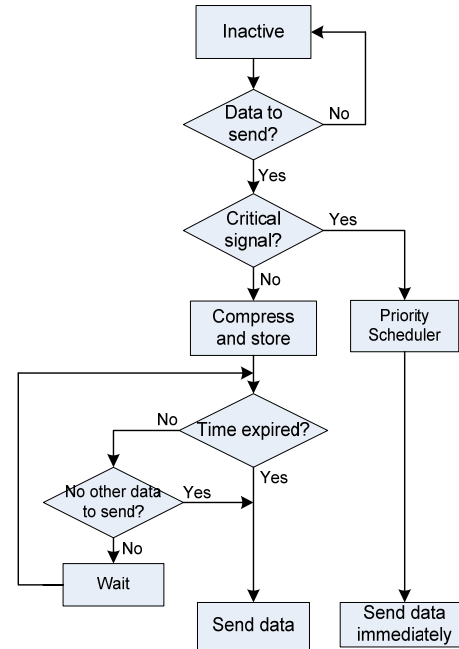

**Figure 3. Differentiated service flow**

For life-threatening medical applications, timely access to the patient's physiological information is crucial for providing correct treatment in time and improving the overall safety of the patient's care. By providing distinguishing services for different physiological signals, the priority scheduling scheme not only reduces the transmission delay for critical physiological signals, but also decreases the probability of traffic congestion. Thus the overall quality of service (QoS) is improved. The number of sent packets is reduced by adopting the data compression scheme. Therefore the bandwidth utilization is improved and the total transmission time is reduced. Since the communication module of the personal server consumes a big proportion of the whole energy, thus the energy can be reduced when the total transmission time is shortened. In a word, by using the differentiated service, the transmission delay of critical physiological signals is reduced and bandwidth utilization is enhanced at the same time. Moreover, the power consumption is reduced.

## 3. AN EXAMPLE USE CASE

With the development of wireless technologies, telemedicine has become practically feasible and increasingly popular. Health telematics applications enable the availability of prompt and professional medical care at understaffed areas like rural health centers, ambulance vehicles, trains, ships and patient home monitoring. With the help of wireless personal area sensor network, complete home patient monitoring becomes technologically feasible and comfortable (figure 4[4]). Moreover,

with this telemedicine system, in-hospital health caring will become more convenient. Physicians and nurses do not need to always stay with patients. They can read and analyze patients' physiological data via telemedicine system and then give diagnosing advice remotely. And staff expense will be reduced subsequently. In this section, an example of patient home monitoring is discussed.

The picture of a telemedicine system for patient home monitoring is shown in figure 4, it is an example taken from [4]. It consists of several medical sensors put on the patient's body, a hand-held personal server, a remote hospital server and related services. The medical sensors which can measure ECG, SpO<sub>2</sub>, body temperature, and blood pressure independently. The sensors and the hand-held personal server form a local personal area network which uses short range, low power protocol IEEE 802.15.4/Zigbee standard. This local personal area network is scalable depending on the medical applications and the number of physiological sensors involved. And the communication between local personal server and remote hospital server uses commercially available 3G communication networks.

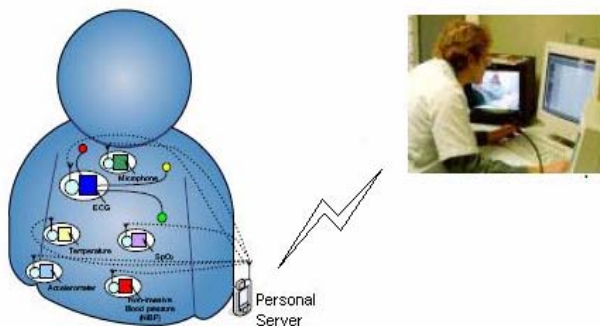

**Figure 4. A telemedicine system[4]**

The whole system works as follows. At first, a physician or nurse-controlled remote hospital server determines when a new measurement is needed, and then it gives commands to the local hand-held personal server via 3G networks. After receiving the commands, the personal server starts to initialize and configure the medical sensors. And then a wireless personal area network (WPAN) is formed automatically. According to the commands from the hospital server, each type of physiological signal is assigned a priority weight which indicates its critical level. And the priority weight can be assigned dynamically depending on the application. (For example, a larger priority weight will be assigned to ECG signals than body temperature for heart disease patient. Then ECG signals will be processed and sent earlier than body temperature if both of them arrived at the personal at the same time). For seriously-sick patients, a threshold of corresponding physiological signal can be pre-set. If the signal exceeds the threshold, the local personal server will generate alarm to inform a care giver or the patient himself. This mechanism improves the safety of patients and reduces staff expense at the same time. The local personal server works in two modes --- active mode and inactive mode. When there is workload, it will wake up from the inactive mode to the active mode. The physiological sensors either automatically or manually triggered to collect required data. The measured physiological signals are transmitted to the personal server via a wireless personal area network (WPAN). The personal server will process and store the

data in local storage for self recording. If required, the signals will be transmitted to the remote hospital server at different orders according to their priorities. After arriving at the hospital server, these data will be analyzed by the physician. And then treatment advices will be given or corresponding measures can be taken.

## 4. CONCLUSION

A network-based system architecture for remote medical applications is introduced in this paper. By using IEEE 802.15.4/Zigbee standard and commercially available 3G networks, this system can be used either at home for continuous monitoring or in hospital for health care with strong scalability and flexibility. According to different emergency levels of physiological signal, a differentiated service based on priority scheduling and data compression is presented. The proposed scheme not only greatly reduces transmission delay for critical physiological signals and enhances bandwidth utilization at the same time, but also reduces power consumption of the hand-held personal server. This mechanism improves quality of service (QoS) of the overall system which is very important for life-critical medical applications. The future work is to build experiment environment based on the proposed system architecture.

## 5. ACKNOWLEDGEMENT

We would like to thank Liping Wang at National Institute of Informatics (NII), Tokyo, Japan, for the fruitful discussions. We also thank the anonymous reviewers for their valuable comments.

## 6. REFERENCES

- [1] B. Woodward, R. S. H. Istepanian, and C. I. Richards, "Design of a telemedicine system using a mobile telephone", *IEEE Trans. on Information Technology in Biomedicine*, vol. 5, no. 1, pp. 13–15, March. 2001.
- [2] Jinwook C., Sooyoung Y., Heekyong P., and Jonghoon C., "MobileMed: A PDA-based mobile clinical information system", *IEEE Trans. on Information Technology in Biomedicine*, vol. 10, no. 3, July 2006.
- [3] Kyriacou E., S. Voskarides, C.S. Pattichis, R. Istepanian, M.S. Pattichis, C.N. Schizas, "Wireless Telemedicine Systems: A brief Overview", 4th International Workshop on Enterprise Networking and Computing in Healthcare Industry (HEALTHCOM2002), Vol. 1, pp. 50-56, Nancy, France, June 2002.
- [4] Lo B., Thiemjarus S., King R., and Yang G., "Body Sensor Network - A Wireless Sensor Platform for Pervasive Healthcare Monitoring", Adjunct Proceedings of the 3rd International conference on Pervasive Computing (PERVASIVE'05), May 2005.
- [5] Milazzo Jr. A.S., Herlong J.R., Li J.S., Sanders S. P., Barrington M., and Bengur A.R., "Real-time transmission of pediatric echocardiograms using a single ISDN line", *Computers in Biology and Medicine*, vol. 32, pp. 379-388, September 2002.
- [6] N. F. Timmons, W. G. Scanlon, "Analysis of the performance of IEEE 802.15.4 for medical sensor body area networking", *IEEE Sensor and Ad Hoc Communications and Networks Conference (SECON)*, 2004.

- [7] N. Smith-Guerin, L. Al Bassit, G. Poisson, C. Delgorge, P. Arbeille, and P. Vieyres, "Clinical validation of a mobile patient-expert tele-echography system using ISDN lines", in Proc. 4th Int. IEEE/EMBS Special Topic Conf. Inform. Technol. Applicat. Biomed., Birmingham, U.K., April 2003, pp. 23–26.
- [8] Pertersen S., Peto V. and Rayner M., "Coronary heart disease statistics 2004", British Heart Foundation, June 2004
- [9] R. S. H. Istepanian, E. Jovanov, Y. T. Zhang, "Guest editorial introduction to the special section on M-health: beyond seamless mobility and global wireless health-care connectivity", IEEE Trans. on Information Technology in Biomedicine, vol. 8, no. 4, December 2004.
- [10] R. S. H. Istepanian, B. Woodward, and C. I. Richards, "Advances in telemedicine using mobile communications", in Proc. 23rd Annu. Int. IEEE/EMBS Conf., Istanbul, Turkey, 2001, pp. 3556–3558.
- [11] Sinem Coleri Ergen, "Zigbee/IEEE 802.15.4 Summary", UC Berkeley, September 2004.  
<http://www.cs.wisc.edu/~suman/courses/838/papers/zigbee.pdf>
- [12] V. Shnayder, B. Chen, "Sensor networks for medical care", Technical Report TR-08-05, Division of Engineering and Applied Science, Harvard University, 2005.  
<http://www.eecs.harvard.edu/~brchen/papers/codeblue-techrept05.pdf>
- [13] W. J. Tompkins, Ed., Biomedical Digital Signal Processing. London, U.K: Prentice-Hall, 1993.
- [14] Yuechun Chu and Aura Ganz, "A mobile teletrauma system using 3G networks", IEEE Trans. on Information Technology in Biomedicine, vol. 8, no. 4, December 2004.